

ABSOLUTE MAXIMUM RATINGS

| Item | Symbol | Min. | Max. | Unit |
|-----------------------|-----------------------------------|------|-----------------------|------|
| Supply Voltage(Logic) | V _{DD} - V _{SS} | -0.3 | 7.0 | V |
| Supply Voltage(LCD) | V _{DD} - V _O | -0.3 | 13.0 | V |
| Input Voltage | V _I | -0.3 | V _{DD} + 0.3 | V |
| Operating Temp. | T _{opr} | -20 | 70 | °C |
| Storage Temp. | T _{stg} | -20 | 80 | °C |

MECHANICAL DATA

| Item | Nominal Dimensions | Unit |
|---------------------------|--------------------|------|
| Module Size (W x H x T) | 75.0 x 26.8 x 14.0 | mm |
| Viewing Area (W x H) | 61.0 x 19.0 | mm |
| Dot Pitch (W x H) | 0.46 x 0.51 | mm |
| Dot Size (W x H) | 0.42 x 0.47 | mm |
| Weight | Approx. 28 | g |

ELECTRICAL CHARACTERISTICS (V_{DD}=5V±0.25V)

| Item | Symbol | Test Condition | Min. | Typ. | Max. | Unit |
|---------------------|----------------------------------|------------------------|----------------------|------|---------------------|------|
| Input High Voltage | V _{IH} | -- | 0.7V _{DD} | -- | V _{DD} | V |
| Input Low Voltage | V _{IL} | -- | 0 | -- | 0.25V _{DD} | V |
| Output High Voltage | V _{OH} | -- | V _{DD} -0.3 | -- | V _{DD} | V |
| Output Low Voltage | V _{OL} | -- | 0 | -- | 0.3 | V |
| Supply Current | I _{DD} | V _{DD} = 5.0V | -- | 3.0 | 3.5 | mA |
| LCD Driving Voltage | V _{DD} - V _O | T _a =25°C | -- | 9.0 | -- | V |

PIN CONNECTIONS

| Pin | Symbol | Level | Function |
|-----|-----------------|-------|----------------------------------|
| 1 | V _{SS} | 0V | GND |
| 2 | V _{DD} | +5V | Power supply for logic |
| 3 | V _O | -- | Operating viltage for LCD |
| 4 | A0 | H/L | H : Data L : Instruction code |
| 5 | R/W | H/L | H : Read L : Write |
| 6 | E1 | H,H>L | Enable signal 1 |
| 7 | DB0 | H/L | Data Bus |
| 8 | DB1 | H/L | |
| 9 | DB2 | H/L | |
| 10 | DB3 | H/L | |
| 11 | DB4 | H/L | |
| 12 | DB5 | H/L | |
| 13 | DB6 | H/L | |
| 14 | DB7 | H/L | |
| 15 | E2 | H,H>L | Enable signal 2 |
| 16 | /RST | L | Reset signal. Active "L". |
| 17 | LEDA | +5V | Power supply for LED backlight |
| 18 | LEDK | 0V | |

BLOCK DIAGRAM

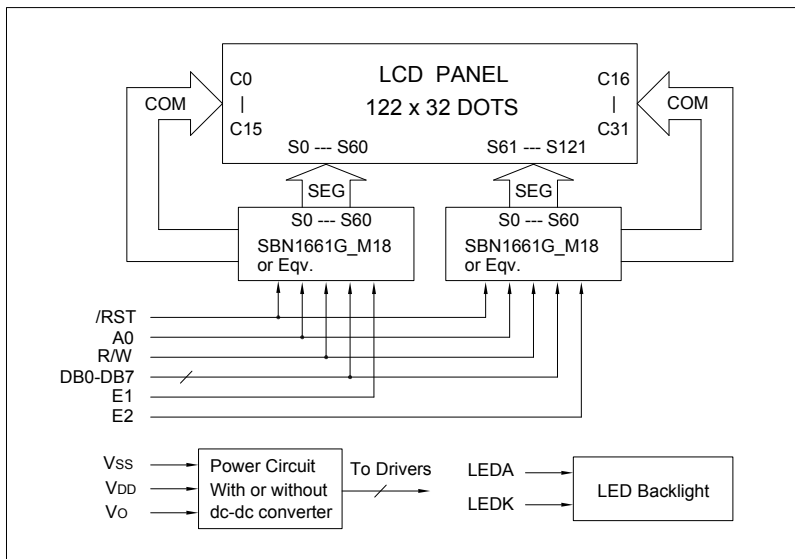

LED BACKLIGHT SPECIFICATIONS (T_a=25°C)

| Item | Symbol | Typ. | Max. | Unit |
|-----------------|----------------|-------|------|------|
| Forward Voltage | V _f | 3.1 | 3.3 | V |
| Forward Current | I _f | 30 | -- | mA |
| LED Color | | White | | |