

LCD Module Specification

Model No.: VS122329-SFDWH6V
VS122329-BMDWH6V

Table of Contents

1. BASIC SPECIFICATIONS	2
2. ABSOLUTE MAXIMUM RATINGS	4
3. ELECTRICAL CHARACTERISTICS	4
4. OPERATING PRINCIPLES & METHODS	7
5. INSTRUCTION CODES	9
6. POWER ON INITIALIZATION	14
7. DISPLAY DATA RAM ADDRESS MAP	15
8. CONNECTION WITH 8051 FAMILY MPU	16
9. ELECTRO-OPTICAL CHARACTERISTICS	17
10. DIMENSIONAL OUTLINE	18
11. LCD MODULE NUMBERING SYSTEM	19
12. PRECAUTIONS FOR USE OF LCD MODULE	20

RECORD OF REVISION

Rev.	Date	Page	Item	Description
0.1	2007/11/12	-	-	New release

VS DISPLAY TECHNOLOGY (HK) LTD

1. BASIC SPECIFICATIONS

1.1 Features

Item		Specifications	Unit
Display Format		122 x 32	dot
LCD Type	SFDWH6V	STN - Yellow Green - Positive - Transflective Dark blue characters on yellow green background	-
	BMDWH6V	STN - Blue - Negative - Transmissive White characters on blue background	-
Driving Method		1/32 Duty, 1/6.7 Bias	-
Viewing Direction		6	O'clock
Backlight & Color		LED, white color	-
Outline Dimension (WxHxT)		75.0 x 26.8 x 14.0	mm
Viewing Area (WxH)		61.0 x 19.0	mm
Active Area (WxH)		56.08 x 16.28	mm
Dot Pitch (WxH)		0.46 X 0.51	mm
Dot Size (WxH)		0.42 X 0.47	mm
Weight		28	g
Controller		SBN1661G_M18 (Compatible with SED1520DOA, AX6120DOA)	-
Interface		8-bit parallel (6800 series MPU)	-
Power Supply (VDD)		5.0 (Built-in voltage converter for LCD driving)	V

1.2 Block Diagram

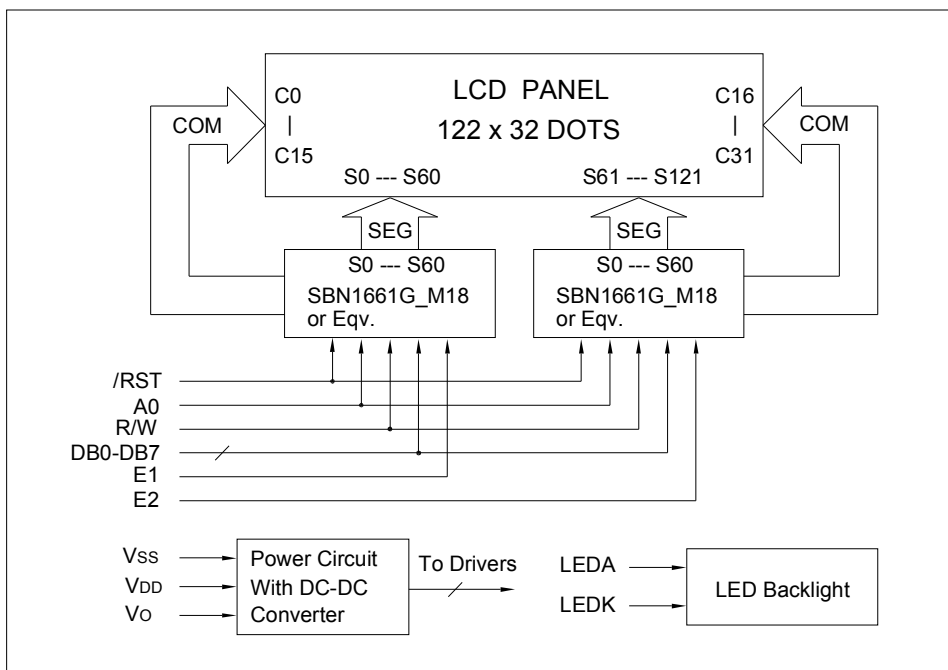

VS DISPLAY TECHNOLOGY (HK) LTD

1.3 Terminal Functions

Pin No.	Symbol	Level	Function
1	VSS	0V	Ground
2	VDD	+5V	Power supply for logic.
3	Vo	-	Operating voltage for LCD (contrast adjusting) Keep this terminal open. Refer to section 3.5
4	A0	H/L	Register selection A0="H": Display data A0="L": Instruction code
5	R/W	H/L	Read/Write selection R/W="H": Read operation R/W="L": Write operation
6	E1	H, H→L	Enable signal for IC1 (left half panel). Read data when E1 is "H", write data at the falling edge of E1.
7	DB0	H/L	Data bus
8	DB1	H/L	
9	DB2	H/L	
10	DB3	H/L	
11	DB4	H/L	
12	DB5	H/L	
13	DB6	H/L	
14	DB7	H/L	
15	E2	H, H→L	Enable signal for IC2 (right half panel). Read data when E2 is "H", write data at the falling edge of E2.
16	/RST	L	Reset signal. Active "L".
17	LEDA	+5V	Power supply for LED backlight.
18	LEDK	0V	Refer to section 3.3, 3.4

VS DISPLAY TECHNOLOGY (HK) LTD

2. ABSOLUTE MAXIMUM RATINGS

Item	Symbol	Min.	Max.	Unit
Supply Voltage (Logic)	VDD-VSS	-0.3	7.0	V
Supply Voltage (LCD)	VDD-VO	-0.3	13.0	V
Input Voltage	VI	-0.3	VDD+0.3	V
Operating Temperature	Topr	-20	70	°C
Storage Temperature	Tstg	-30	80	°C

3. ELECTRICAL CHARACTERISTICS

3.1 DC Characteristics (Ta=25°C)

Item	Symbol	Condition	Min.	Typ.	Max.	Unit
Supply Voltage (Logic)	VDD		4.9	5.0	5.1	V
Supply Voltage (LCD Drive)	VDD-VO		-	9.0	-	V
Input High Voltage	VIH		0.7VDD	-	VDD	V
Input Low Voltage	VIL		0	-	0.25VDD	V
Output High Voltage	VOH		VDD-0.3	-	VDD	V
Output Low Voltage	VOL		0	-	0.3	V
Supply Current (Logic)	IDD	VDD=5.0V	-	3.0	3.5	mA

VS DISPLAY TECHNOLOGY (HK) LTD

3.2 Interface Timing Chart

(VDD=5.0V±10%, Ta=25°C)

Parameters		Signal	Symbol	Min.	Max.	Condition	Unit
System Cycle Time		A0, R/W	t_{CYC6}	1000	-		ns
Address Set-up Time			t_{AW6}	20	-		
Address Hold Time			t_{AH6}	10	-		
Enable Pulse Width	Read	E	t_{EW}	100	-		
	Write			80	-		
Data Set-up Time		DB0-DB7	t_{DS6}	80	-		
Data Hold Time			t_{DH6}	10	-		
Output Disable Time			t_{OH6}	10	60		
Access Time			t_{ACC6}	-	90		

Note: Each of the values when VDD=3.3V is about 200% of that when VDD=5.0V.

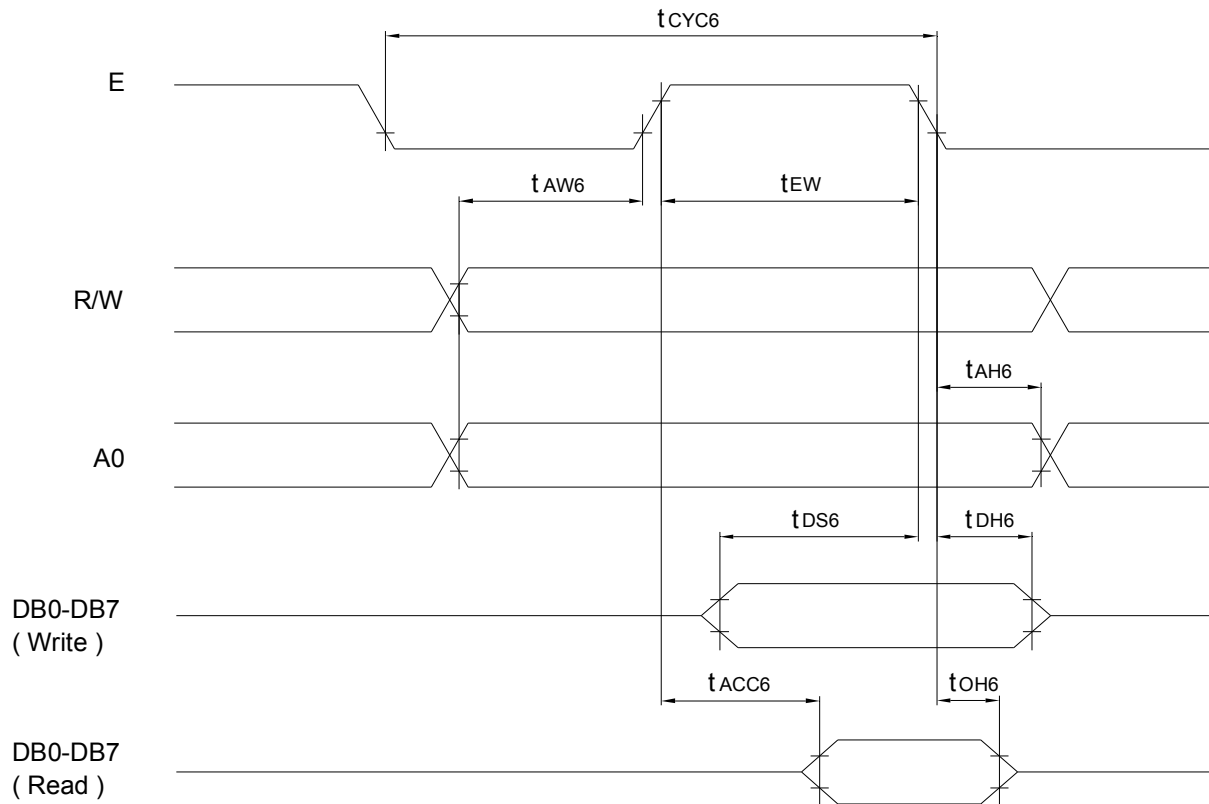

VS DISPLAY TECHNOLOGY (HK) LTD

3.3 LED Backlight Characteristics (Ta=25°C)

Item	Symbol	Condition	Min.	Typ.	Max.	Unit
Forward Voltage	Vf		2.9	3.1	3.3	V
Forward Current	If	Vf=3.1V	-	30	-	mA
Color	White					

3.4 Power Supply for LED Backlight

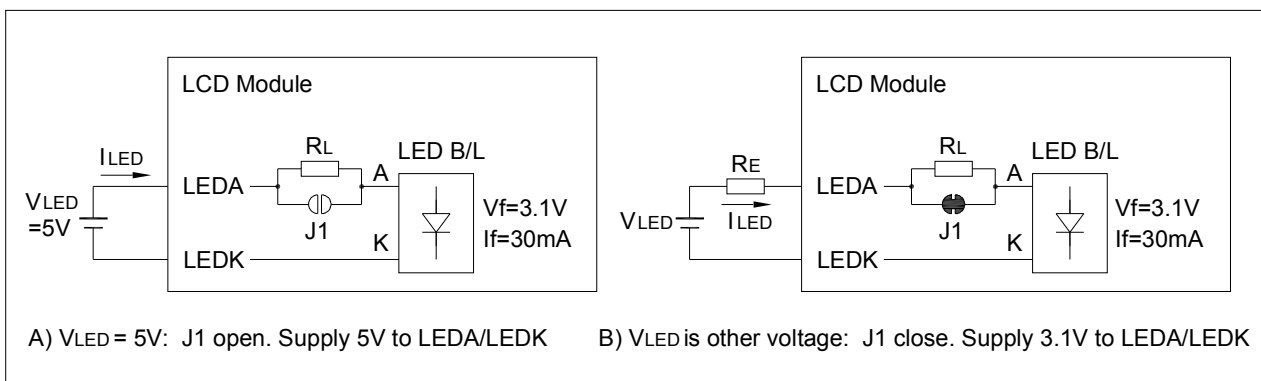

* RL (internal) and RE (external) are the current limiting resistors for LED backlight

- 1) $V_{LED}=5.0V$: J1 open. Supply 5.0V to LEDA (Pin 17) and LEDK (Pin 18) **<Default>**
- 2) $V_{LED}=3.3V$: J1 close; $RE=(3.3V-3.1V)/30mA=7\Omega$. Supply 3.1V to LEDA (Pin 17) and LEDK (Pin 18)
- 3) V_{LED} is other voltage: J1 close; $RE=(V_{LED}-3.1V)/30mA$. Supply 3.1V to LEDA (Pin 17) and LEDK (Pin 18)

3.5 Power Supply for Logic and LCD Driving

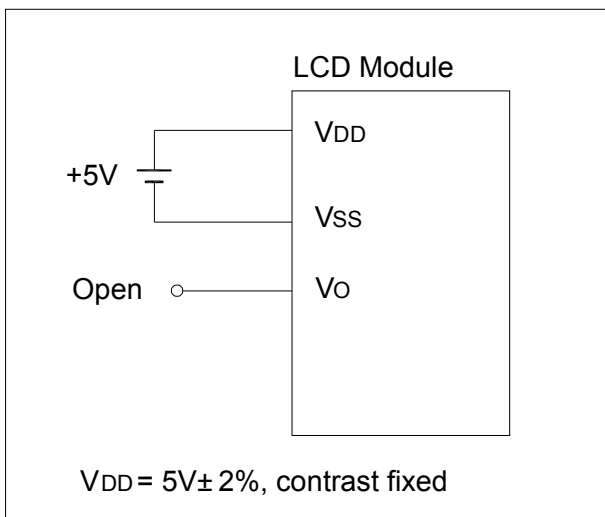

* The contrast is fixed for this LCD module; do not make any connection to Vo terminal.

VS DISPLAY TECHNOLOGY (HK) LTD

4. OPERATING PRINCIPLES & METHODS

4.1 Identification of data bus signal

The SBN1661_M18 uses a combination of A0, E, R/W to identify the data bus signal.

A0	R/W	Function
0	0	Instruction write
	1	Status read (busy check)
1	0	Display data write (from MPU to the display data RAM)
	1	Display data read (from the display data RAM to MPU)

When read (R/W=1), display data or status appears at DB0 to DB7 while E is in “H” level. When write (R/W=0), display data or instruction code at DB0 to DB7 is latched to SBN1661_M18 at the falling edge of E.

4.2 Access to Display Data RAM and Internal Register

The SBN1661_M18 is operating as one of pipe-line processor by the bus-holder connecting to the internal data bus to adjust the operation frequency between MPU and the display data RAM or internal register.

When MPU writes data into the display data RAM, the data is held in the bus-holder at first, and then written into the display data RAM automatically by internal operation.

In the case when MPU reads the content of the display data RAM, in the first data read cycle (dummy), the data is stored on the bus-holder. In the next data read cycle, the data is read from the bus-holder to the system bus. Therefore, one dummy read is required after address setting or write cycle.

4.3 Busy Flag

When internal circuits are in the operation mode, the Busy Flag (BF) is “1”, and any instruction other than Read Status is inhibited. The busy flag is output at D7 terminal by the Read Status instruction.

4.4 Display Start Line Register

The display start line register is a pointer register which indicates the address in the display data RAM corresponding to COM0 (normally it displays the top line of the LCD panel). It is used for scrolling the display or changing the page from one to another. Executing the Set Display Start Line instruction sets 5 bits of display start address in this register.

VS DISPLAY TECHNOLOGY (HK) LTD

4.5 Column Address Counter

The column address counter is a 7-bit presettable counter which gives column address of the display data RAM. The counter increases "1" when the Read/Write Display Data instruction is executed. The count up stops at 50H (over 50H is non existing address) automatically by the count lock function.

The column address counter is independent from the page register.

4.6 Page Register

This register gives page address of the display data RAM. The Set Page Address instruction permits the MPU to access a new page of the display data RAM.

4.7 Display Data RAM

Display Data RAM stores the bit image display data (each bit corresponds to a pixel on the LCD panel). Since the MPU and LCD driver circuit operate independently of each other, data can be changed asynchronously without adverse effect on the display.

One bit of the display data RAM is assigned to one dot of LCD:

LCD on = "1"

LCD off = "0"

The ADC Select instruction inverts the assignment relationship between the display data RAM column address and the segment output.

4.8 Reset Circuit

The SBN1661_M18 performs following initialization by detecting the rising edge of /RST terminal after the power turns on:

- (a) Display off
- (b) Display start line register: First line
- (c) Static drive off
- (d) Column address counter: Address 0
- (e) Page address register: Page 0
- (f) Select duty: 1/32
- (g) Select ADC: Forward (ADC instruction D0 = "0", ADC status flag = "1")
- (h) Read modify write mode off

By the Reset instruction, the initialization of (b), (d) and (e) mentioned above are executed.

VS DISPLAY TECHNOLOGY (HK) LTD

6. INSTRUCTION CODES

Instruction	Code										Description	
	A0	R/W	D7	D6	D5	D4	D3	D2	D1	D0		
Display On/Off	0	0	1	0	1	0	1	1	1	0/1	Whole Display On/Off. 1: On 0: Off (power save mode if the static drive on)	
Display Start Line	0	0	1	1	0	Display Start Address (0—31)					Determine the display line corresponding to the COM0.	
Page Address Set	0	0	1	0	1	1	1	0	Page (0-3)		Set the page of display data RAM to the page register.	
Column Address Set	0	0	0	Column Address (0—79)								Set the column address of display data RAM to the column register.
Status Read	0	1	B U S Y	A D C	O N / O F F	R E S E T	0	0	0	0	Read the status: BUSY 1: Internal operating 0: Ready ADC 1: CW output (forward) 0: CCW output (reverse) ON/OFF 1: Display Off, 0: Display on RESET 1: Reset, 0: Normal	
Write Display Data	1	0	Write Data								Write data to the display data RAM.	Access the predetermined address of the display data RAM. The column address increases "1" after read or write.
Read Display Data	1	1	Read Data								Read data from the display data RAM.	
ADC Select	0	0	1	0	1	0	0	0	0	0/1	Used to invert relationship of assignment between display RAM column addresses and segment driver outputs. 0: CW output (forward) 1: CCW output (reverse)	
Static Drive On/Off	0	0	1	0	1	0	0	1	0	0/1	Select normal display or static driving operation. 1: Static driving (power saving) 0: Normal driving	
Duty Ratio Select	0	0	1	0	1	0	1	0	0	0/1	Selects the duty ratio. 1: 1/32 Duty 0: 1/16 Duty	
Read Modify Write	0	0	1	1	1	0	0	0	0	0	Increase column address counter by "1" when display data is written but no change when data is read.	
End	0	0	1	1	1	0	1	1	1	0	Release from the read modify write mode.	
Reset	0	0	1	1	1	0	0	0	1	0	Set the display start line register to 1st line, column address register and page address register to "0".	
Power Save (Dual command)	0 0	0 0	1 1	0 0	1 1	0 0	1 0	1 1	1 0	0 1	Set the power save mode by selecting display off and static driving on.	

VS DISPLAY TECHNOLOGY (HK) LTD

5.1 Display On/Off

A0	E	R/W	DB7	DB6	DB5	DB4	DB3	DB2	DB1	DB0
0	1	0	1	0	1	0	1	1	1	D

D = 0 : Display off

D = 1 : Display on

This instruction executes whole display on/off no relation with the data in the display data RAM and internal conditions.

When the static driving mode is selected (static drive on) in display off status, the internal circuit put on the power save mode.

5.2 Display Start Line

A0	E	R/W	DB7	DB6	DB5	DB4	DB3	DB2	DB1	DB0
0	1	0	1	1	0	A4	A3	A2	A1	A0

This instruction sets the line address in the display data RAM corresponding to COM0 which display at the top line of LCD panel. Display begins with the specified line address and covers as many lines as matching the display duty in address ascending order.

Therefore, the smooth scroll for vertical direction by changing the start line address one by one or page switching are available by this instruction.

5.3 Page Address Set

A0	E	R/W	DB7	DB6	DB5	DB4	DB3	DB2	DB1	DB0
0	1	0	1	0	1	1	1	0	A1	A0

When MPU accesses the display data RAM, the page address corresponding to the row address must be selected. The access in the display data RAM is available by setting the page and column address. Changing the page address causes no change in display.

5.4 Column Address Set

A0	E	R/W	DB7	DB6	DB5	DB4	DB3	DB2	DB1	DB0
0	1	0	0	A6	A5	A4	A3	A2	A1	A0

This instruction sets the column address in the display data RAM. When the MPU accesses the display data RAM continuously, the column address increases "1"

VS DISPLAY TECHNOLOGY (HK) LTD

automatically. The increment of the column address is stopped by the address of 50H automatically, but the page address is not changed even if the column address increases to 50H.

5.5 Status Read

A0	E	R/W	DB7	DB6	DB5	DB4	DB3	DB2	DB1	DB0
0	1	1	BUSY	ADC	ON/OFF	RESET	0	0	0	0

This instruction reads out the internal status.

BUSY : BUSY="1" means that the system is performing an internal operation or is in reset cycle. No instruction is accepted before BUSY = "0".

ADC : Indicates the output correspondence of column addresses to segment drivers.

0: Inverted (column address 79-n \leftrightarrow segment driver n)

1: Forward (column address n \leftrightarrow segment driver n)

ON/OFF: Indicates whole display on or off.

0: Whole display on

1: Whole display off

Note: The data "0=On" and "1=Off" of Display On/Off status read out is inverted with the Display On/Off instruction data of "1=On" and "0=Off".

RESET : Indicates that system is being initialized by the /RST signal or Reset instruction.

0: Display mode

1: Being reset

5.6 Write Display Data

A0	E	R/W	DB7	DB6	DB5	DB4	DB3	DB2	DB1	DB0
1	1	0	D7	D6	D5	D4	D3	D2	D1	D0

This instruction writes the 8-bit data from MPU to the display data RAM. The column address increases "1" automatically when writing.

5.7 Read Display Data

A0	E	R/W	DB7	DB6	DB5	DB4	DB3	DB2	DB1	DB0
1	1	1	D7	D6	D5	D4	D3	D2	D1	D0

This instruction reads out the 8-bit data from the display data RAM addressed by the column and page address. In case of the Read Modify Mode is off, the column address

VS DISPLAY TECHNOLOGY (HK) LTD

increases "1" automatically after each read out.

One time of dummy read must be required after column address setting.

5.8 ADC Select

A0	E	R/W	DB7	DB6	DB5	DB4	DB3	DB2	DB1	DB0
0	1	0	1	0	1	0	0	0	0	D

D = 0: Clockwise output (forward)

D = 1: Counterclockwise output (reverse)

This instruction sets the correspondence of column address in the display data RAM and segment driver output. In other words, the Select ADC instruction can software-invert the order of segment driver output pins, this makes IC layout flexible in LCD module assembly.

5.9 Static Drive On/Off

A0	E	R/W	DB7	DB6	DB5	DB4	DB3	DB2	DB1	DB0
0	1	0	1	0	1	0	0	1	0	D

D = 0: Static drive off (Normal operation)

D = 1: Static drive on (Whole display turns on)

This instruction forces all display to be on and, at the same time, all common output to be selected.

When the Display Off mode is selected (Display Off) in static drive on status, the internal circuits put on the power save mode.

5.10 Duty Select

A0	E	R/W	DB7	DB6	DB5	DB4	DB3	DB2	DB1	DB0
0	1	0	1	0	1	0	1	0	0	D

D = 0: 1/16 Duty

D = 1: 1/32 Duty

This instruction sets the LCD driving duty ratio.

5.11 Read Modify Write

A0	E	R/W	DB7	DB6	DB5	DB4	DB3	DB2	DB1	DB0
0	1	0	1	1	1	0	0	0	0	0

VS DISPLAY TECHNOLOGY (HK) LTD

This instruction is used with the End instruction in pair. Once it has been entered, the column address increases “1” automatically when display data write instruction is executed, but the address is not changed when the display data read instruction is executed. This mode will stay until the End instruction is entered. When the End instruction is entered the column address returns to the address where the Read Modify Write instruction was entered. This function lessens the load of the MPU when the data in a specific display area are repeatedly updated (as blinking cursor).

Even in the Read Modify Write mode, any instruction other than Column Address Set can be used.

5.12 End

A0	E	R/W	DB7	DB6	DB5	DB4	DB3	DB2	DB1	DB0
0	1	0	1	1	1	0	1	1	1	0

This instruction releases the Read Modify Write mode and the column address returns to the address where the Read Modify Write mode is entered.

5.13 Reset

A0	E	R/W	DB7	DB6	DB5	DB4	DB3	DB2	DB1	DB0
0	1	0	1	1	1	0	0	0	1	0

This instruction executes the following initialization without changing the display data RAM:

- (a) Sets the 1st line in the display start line register.
- (b) Sets the page 3 in the page register.

5.14 Power Save (Dual Command)

When both of display off and static drive on are executed, the internal circuits put on the power save mode and the current consumption is reduced as same as stand by current.

The internal status in this mode is as follows:

- (a) Stop the LCD driving. Segment and common drivers output VDD level.
- (b) Stop the oscillation or inhibit the external clock input.
- (c) Keep the display data and operating mode.

The power save mode is released by display on or static drive off instruction.

A resistor division circuit is used to give LCD driving voltage level. To reduce the total current consumption, the current flowing into the resistors must be cut off by the power save signal.

VS DISPLAY TECHNOLOGY (HK) LTD

6. POWER ON INITIALIZATION

When power on, take the following sequence to initialize the LCD module.

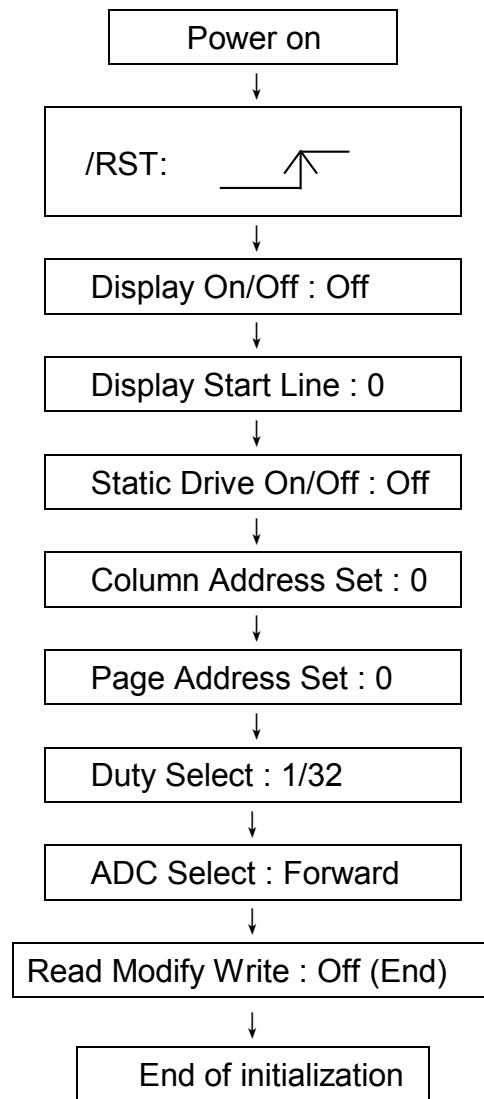

VS DISPLAY TECHNOLOGY (HK) LTD

7. DISPLAY DATA RAM ADDRESS MAP

Page Address A1, A0=	Display Data	1st SBN1661_M18 (E1=H, E2=L)						2nd SBN1661_M18 (E1=L, E2=H)						Line Address	Common	
0, 0	D0													00	COM0	
	D1													01	COM1	
	D2													02	COM2	
	D3													03	COM3	
	D4													04	COM4	
	D5													05	COM5	
	D6													06	COM6	
	D7													07	COM7	
0, 1	D0													08	COM8	
	D1													09	COM9	
	D2													0A	COM10	
	D3													0B	COM11	
	D4													0C	COM12	
	D5													0D	COM13	
	D6													0E	COM14	
	D7													0F	COM15	
1, 0	D0													10	COM16	
	D1													11	COM17	
	D2													12	COM18	
	D3													13	COM19	
	D4													14	COM20	
	D5													15	COM21	
	D6													16	COM22	
	D7													17	COM23	
1, 1	D0													18	COM24	
	D1													19	COM25	
	D2													1A	COM26	
	D3													1B	COM27	
	D4													1C	COM28	
	D5													1D	COM29	
	D6													1E	COM30	
	D7													1F	COM31	
Column Address	A D C	D=0	00	01	02	--	3A	3B	3C	00	01	02	--	3A	3B	3C
		D=1	4F	4E	4D	--	15	14	13	4F	4E	4D	--	15	14	13
Segment		SEG0	SEG1	SEG2	-	SEG58	SEG59	SEG60	SEG61	SEG62	SEG63	-	SEG119	SEG120	SEG121	

LCD PANEL
122 X 32 DOTS

VS DISPLAY TECHNOLOGY (HK) LTD

8. CONNECTION WITH 8051 FAMILY MPU

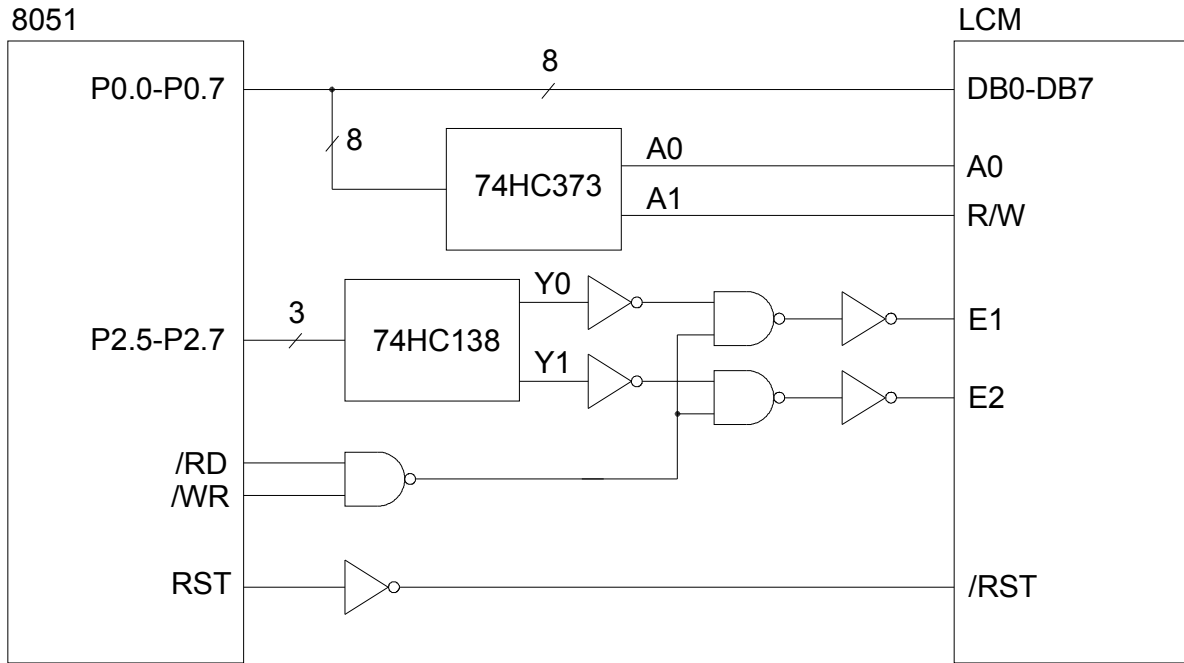

a. Application Circuit 1

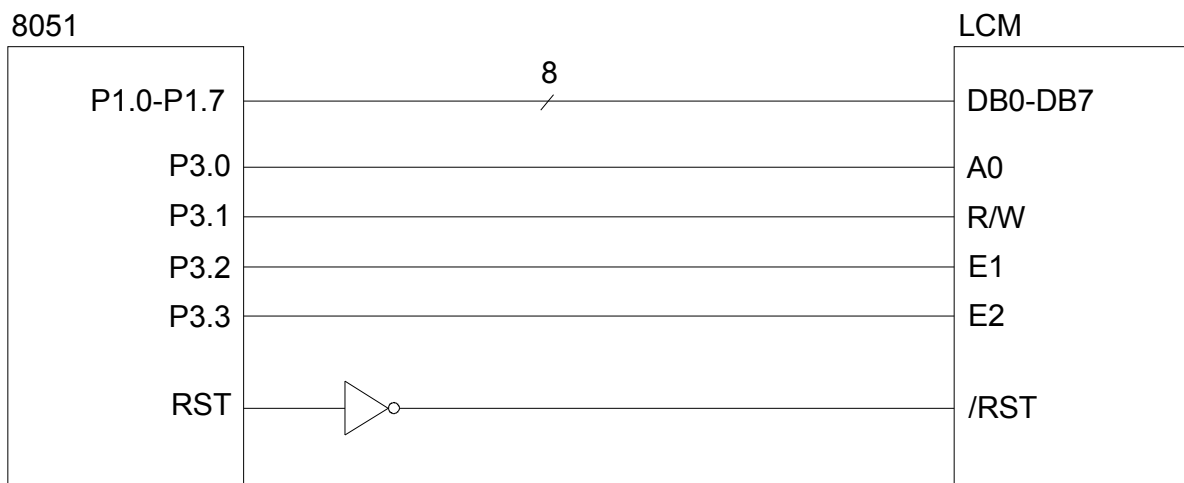

b. Application Circuit 2

VS DISPLAY TECHNOLOGY (HK) LTD

9. ELECTRO-OPTICAL CHARACTERISTICS ($T_a=25^\circ\text{C}$)

Item	Symbol	Condition	Min.	Typ.	Max.	Unit	Note
View Angle	$\Phi_2-\Phi_1$	$Cr \geq 2, \theta=0^\circ$	-	70	-	Deg	Note1, Note2
Contrast Ratio	Cr	$\Phi=0^\circ, \theta=0^\circ$	3	-	-	-	Note3
Response Time	tr (rise)	$\Phi=0^\circ, \theta=0^\circ$	-	200	-	ms	Note4
	tf (fall)	$\Phi=0^\circ, \theta=0^\circ$	-	250	-	ms	

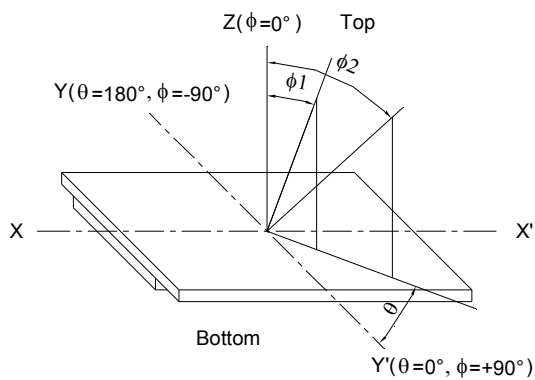

Note1: Definition of viewing angle ϕ, θ

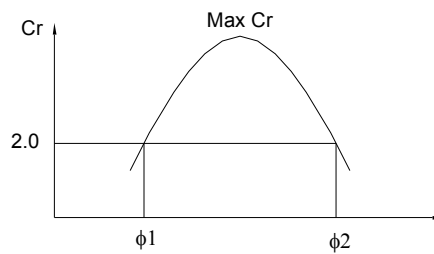

Note2: Definition of viewing angle range ϕ_1, ϕ_2

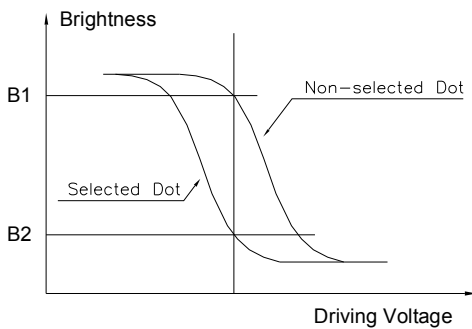

$$\text{Contrast Ratio} = \frac{\text{Brightness of non-selected dot (B1)}}{\text{Brightness of selected dot (B2)}}$$

Note3: Definition of contrast ratio (positive type)

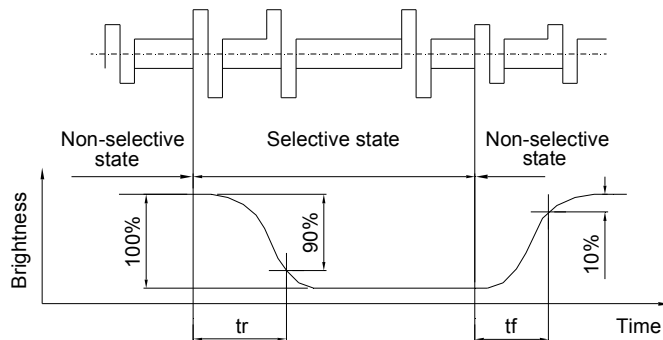

Note3: Definition of response time

10. DIMENSIONAL OUTLINE

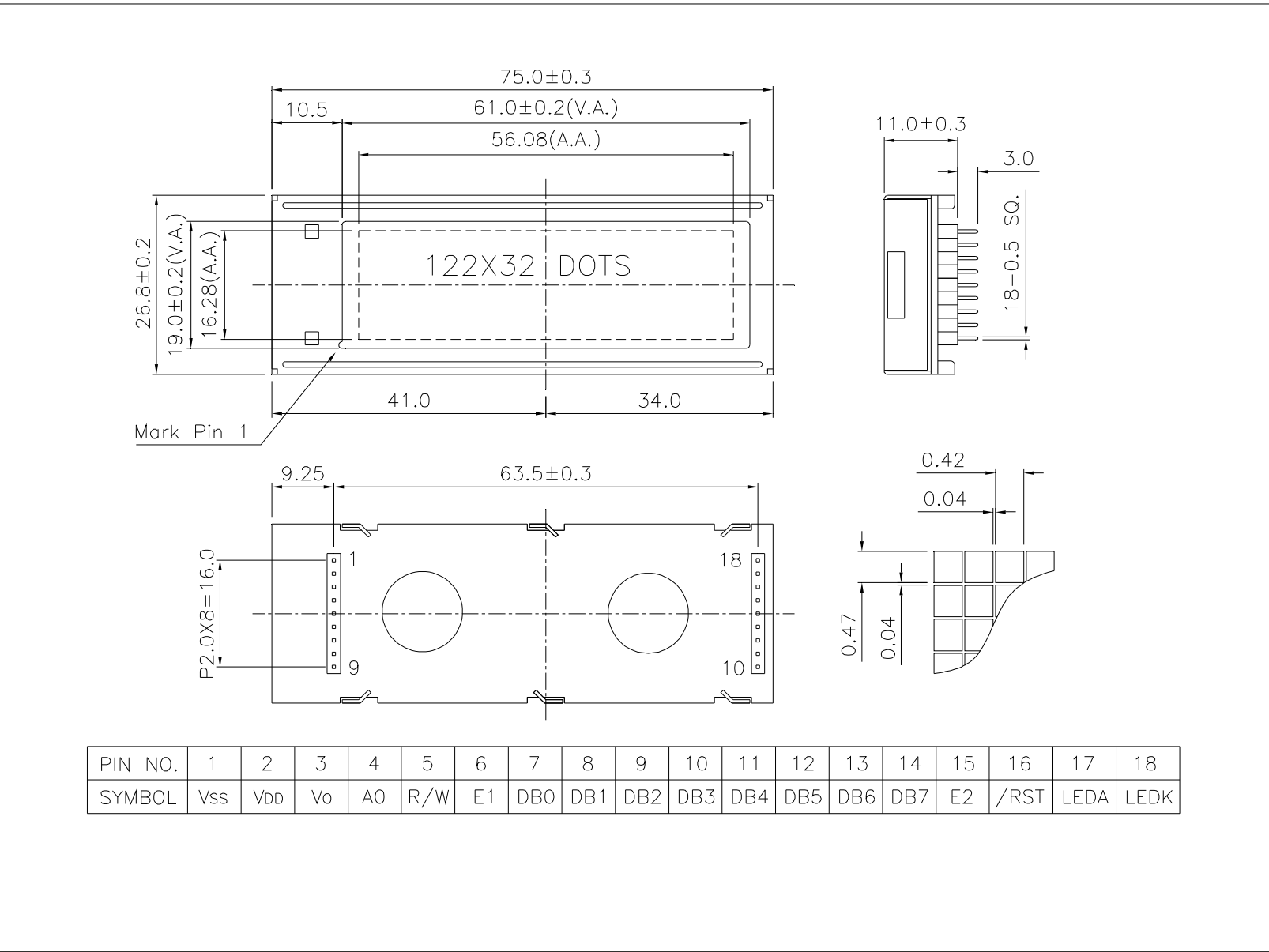

VS DISPLAY TECHNOLOGY (HK) LTD

11. LCD MODULE NUMBERING SYSTEM

V S 122 32 9 - S F D W H 6 V - XXXXX
(1) (2) (3) (4) (5) (6) (7) (8) (9) (10) (11) (12) (13)

(1) Brand

(2) Module type

C - Character module

G - Graphic module

(3) Display format

Character module : Number of characters per line, two digits XX

Graphic module : Number of columns, three digits XXX

(4) Display format

Character module : Number of lines, one digit X

Graphic module : Number of rows, two or three digits XX or XXX

(5) Development number : One or two digits X or XX

(6) LCD mode

T - TN Positive, Gray

N - TN Negative, Blue

S - STN Positive, Yellow green

G - STN Positive, Gray

B - STN Negative, Blue

F - FSTN Positive, White

K - FSTN Negative, Black

L - FSTN Negative, Blue

Q - FSTN Negative, Black

(7) Polarizer mode

R - Reflective

F - Transflective

M - Transmissive

(8) Backlight type

N - Without backlight

L - Array LED

D - Edge light LED

E - EL

C - CCFL

(9) Backlight color

Y - Yellow green

B - Blue

W - White

G - Green

A - Amber

R - Red

M - Multi color

Nil - Without backlight

(10) Operating temperature range

S - Standard temperature (0 to +50 °C)

H - Extended temperature (-20 to +70 °C)

(11) Viewing direction

3 - 3:00

6 - 6:00

9 - 9:00

U - 12:00

(12) DC-DC Converter

N or Nil - Without DC-DC converter

V - Built in DC-DC converter

(13) Version code

Nil or 0 to ZZZZZ - Version code

VS DISPLAY TECHNOLOGY (HK) LTD

12. PRECAUTIONS FOR USE OF LCD MODULE

12.1 Handling Precautions

- 1) The display panel is made of glass. Do not subject it to a mechanical shock by dropping it from a high place, etc.
- 2) If the display panel is damaged and the liquid crystal substance inside it leaks out, be sure not to get any in your mouth. If the substance comes into contact with your skin or clothes, promptly wash it off using soap and water.
- 3) Do not apply excessive force on the surface of display or the adjoining areas of LCD module since this may cause the color tone to vary.
- 4) The polarizer covering the display surface of the LCD module is soft and easily scratched. Handle this polarizer carefully.
- 5) If the display surface of LCD module becomes contaminated, blow on the surface and gently wipe it with a soft dry cloth. If it is heavily contaminated, moisten cloth with one of the following solvents.
 - Isopropyl alcohol
 - Ethyl alcoholSolvents other than those mentioned above may damage the polarizer.
Especially, do not use the following:
 - Water
 - Ketone
 - Aromatic Solvents
- 6) When mounting the LCD module make sure that it is free of twisting, warping, and distortion. Distortion has great influence upon display quality. Also keep the stiffness enough regarding the outer case.
- 7) Be sure to avoid any solvent such as flux for soldering never stick to Heat-Seal. Such solvent on Heat-Seal may cause connection problem of heat-Seal and TAB.
- 8) Do not forcibly pull or bend the TAB I/O terminals.
- 9) Do not attempt to disassemble or process the LCD module.
- 10) NC terminal should be open. Do not connect anything.
- 11) If the logic circuit power is off, do not apply the input signals.
- 12) To prevent destruction of the elements by static electricity, be careful to maintain an optimum work environment.
 - Be sure to ground the body when handling the LCD module.
 - Tools required for assembly, such as soldering irons, must be properly grounded.
 - To reduce the amount of static electricity generated, do not conduct assembly and other work under dry conditions.
 - The LCD module is coated with a film to protect the display surface. Exercise care when peeling off this protective film since static electricity may be generated.

12.2 Storage Precautions

- 1) When storing the LCD module, avoid exposure to direct sunlight or to the light of fluorescent lamps and high temperature/high humidity. Whenever possible, the LCD module should be stored in the same conditions in which they were shipped from our company.

VS DISPLAY TECHNOLOGY (HK) LTD

- 2) Exercise care to minimize corrosion of the electrodes. Corrosion of the electrodes is accelerated by water droplets or a current flow in a high humidity environment.

12.3 Design Precautions

- 1) The absolute maximum ratings represent the rated value beyond which LCD module can not exceed. When the LCD modules are used in excess of this rated value, their operating characteristics may be adversely affected.
- 2) To prevent the occurrence of erroneous operation caused by noise, attention must be paid to satisfy VIL, VIH specification values, including taking the precaution of using signal cables that are short.
- 3) The liquid crystal display exhibits temperature dependency characteristics. Since recognition of the display becomes difficult when the LCD is used outside its designated operating temperature range, be sure to use the LCD within this range. Also, keep in mind that the LCD driving voltage levels necessary for clear displays will vary according to temperature.
- 4) Sufficiently notice the mutual noise interference occurred by peripheral devices.
- 5) To cope with EMI, take measures basically on outputting side.
- 6) If DC is impressed on the liquid crystal display panel, display definition is rapidly deteriorated by the electrochemical reaction that occurs inside the liquid crystal display panel. To eliminate the opportunity of DC impressing, be sure to maintain the AC characteristics of the input signals sent to the LCD Module.

12.4 Others

- 1) Liquid crystals solidify under low temperatures (below the storage temperature range) leading to defective orientation or the generation of air bubbles (black or white). Air bubbles may also be generated if the LCD module is subjected to a strong shock at a low temperature.
- 2) If the LCD modules have been operating for a long time showing the same display patterns, the display patterns may remain on the screen as ghost images and a slight contrast irregularity may also appear. A normal operating status can be regained by suspending use for some time. It should be noted that this phenomenon does not adversely affect performance reliability.
- 3) To minimize the performance degradation of the LCD modules resulting from destruction caused by static electricity, etc., exercise care to avoid touching the following sections when handling the module:
 - Terminal electrode sections.
 - Part of pattern wiring on TAB, etc.